

1.0 GENERAL INFORMATION RELATIVE TO THIS SCHEDULE

- 1.1 This Schedule shall be read in its entirety and shall take precedence over Appendix 2 Schedule A or Appendix 5 Schedule DR of the 'National Sporting Code' excepting where an item is not specifically covered within Schedule D1, in which case Appendix 2 Schedule A or Appendix 5 Schedule DR will apply.
- 1.2 All text changes from the previous issue of this Schedule are highlighted such. Text changes for grammatical and/or formatting reasons are not highlighted.
- 1.3 All cars competing in Events to which these regulations apply shall have a valid MotorSport NZ logbook.
- 1.4 These regulations shall be interpreted on the basis that if a modification is not specifically permitted, then it is not allowed. The limits of the permitted modifications are specified herein after.
- 1.5 **TECHNICAL ELIGIBILITY AND SAFETY EQUIPMENT ENQUIRY:** Where any doubt may exist in understanding any regulation contained within this Schedule it will be understood that it is the Competitors obligation to enquire as to the correct interpretation. All technical eligibility and/or safety equipment enquiry shall be submitted in writing to:
- (1) The Series Scrutineer, as detailed in the Series Articles, then to
 - (2) The MotorSport NZ Technical Department
 - All enquiries should detail the article in question and the specific subject matter.
 - A written reply will always be given to a written enquiry.
 - On matters of technical eligibility and/or safety compliance, a verbal statement will have no validity.

2.0 DEFINITIONS

- 2.1 Definition of terms used within this Schedule shall be referenced from the National Sporting Code, Appendix Two Schedule A, and as detailed below:
- 'Exterior body panel'** means any exterior finished panel of the original OEM vehicle that is visible from the outside of the Vehicle.
- 'Lightweight'** means constructed of materials that are lighter than the Original or a component, which has had material, removed.
- 'Original'** means the factory fitted part for that make, model and year.
- 'Race trim'** means the condition in which the car competes, and shall include all fluids, ballasts and the driver.

3.0 ELIGIBLE VEHICLES

- 3.1 All Vehicles must be of 'Series Production Vehicle' unitary construction.
- 3.2 All Vehicles must originally be of FR, MR or 4WD designation. Only rear-wheel drive vehicles are eligible to enter the Series.
- 3.3 Utes that are rear wheel drive and comply with Appendix 5 Schedule DR are permitted to enter the Series.

- 3.4 Maintenance of Eligibility:** it is the responsibility of the Competitor to maintain the vehicle's eligibility.
- 3.5** Vehicles are categorised into the following classes as detailed in the Series Articles:
- (1) Pro-Class
 - (2) Pro-Sport Class

4.0 SAFETY EQUIPMENT REQUIREMENTS

- 4.1** The following safety equipment **shall** be fitted to the competing car:
- 4.1.1 Safety harness:** for each seat fitted shall be a minimum of four(4) strap harness, compliant to either FIA or SFI standard, installed in full compliance with Appendix Two, Schedule A.
- 4.1.2 Seats:** all seats must be Competition Seat(s) compliant to FIA standard, installed in full compliance with Appendix Two, Schedule A Article 4.7(2)(c).
- 4.1.3 A Safety Cage:** shall be fitted as per Appendix Two, Schedule A requirements. Additionally, side intrusion shall be installed adjacent to any occupants.
- 4.1.4 Fire extinguisher(s):** shall be installed in full compliance with Appendix Two, Schedule A.
- 4.1.5 Windscreens:** shall comply fully with the requirements of Appendix Two, Schedule A. The
- 4.2** following safety equipment **may** be fitted to the competing car:
- (1) It is recommended that vehicles be fitted with safety hoops surrounding the centre drive shaft
 - (2) Window nets **must** be fitted adjacent to any occupants in the place of absent windows. It is recommended that window nets comply with either FIA standard or SFI specification, and are installed with a quick release system operable from both inside and outside the vehicle. Window nets should be installed so as not to obscure vision during competition.

5.0 BODY and CHASSIS SPECIFICATIONS

- 5.1 Body Shell:**
- (1) Bodywork may be manufactured from lightweight materials.
 - (2) The Vehicles side profile shall remain Standard with the exception of the front bumper, rear bumper, rear spoiler, side skirts and wing.
 - (3) Front and rear spoilers / wings are permitted. Front spoilers may include the front bumper. Front spoiler under-trays are allowed to extend back to the front suspension cross member (in line with the centre of the front axles). This is the only form of under-tray allowed.
 - (4) Wheel arch flares and aftermarket front/rear guards not exceeding 150mm width per side overall may be fitted.
 - (5) Side skirt panels may be fitted.
 - (6) Ducting for the purpose of the flow of cooling air for brakes and radiators is free, provided that such ducting does not alter the profile of the Vehicle and further providing that such ducting does not directly or indirectly assist or improve aerodynamic or ground effects.

- (7) Bonnets may be modified for the purpose of venting / cooling provided compliance with Schedule A is retained. Subject to approval by the Series Scrutineer, bonnets may be modified to allow the passage of mechanical components. Such modification shall be contained to the minimum required to provide clearance and may require the addition of covers or shielding.
- (8) All bumpers, panels, bonnets and associated bodywork shall be fitted on all competition vehicles at any time on the circuit. All bodywork must be in place at the commencement of all qualifying and competition events. This includes bumpers, side skirts and bonnets.
- (9) The bodywork shall be neatly designed, complete and finished without temporary or makeshift elements as per Schedule A.
- (10) Window tints are allowed on the side and rear windows, providing they do not exceed LTSA standards on the Driver and passenger front door glass. Tinting is not permitted on windscreens below the sunvisor / banner line.
- (11) Aftermarket, non-OEM vertical planes/fins added to a competition vehicle may not exceed 2500mm². Vertical side plates that come standard with any commercially available and marketed aftermarket rear spoiler does not count towards the 2500mm² limit unless it is secured by any other part of the Vehicle other than the rear spoiler.
- (12) Headlight/front end conversions (such as a Sileighty, Cefline, R34, AU Falcon front conversions etc) are allowed provided no modification is made to the chassis rails, firewall and/or suspension pickup points.
- (13) Aftermarket Gull Wing door kits are not allowed.
- (14) All Open Vehicles (ie MX5, S2000 etc) shall have suitable Hard Top roofs fitted.

5.2 Tow Hooks: Front and rear tow hooks must be fitted onto all competition vehicles and;

- (1) Have their position clearly indicated.
- (2) Have a minimum internal diameter of 40mm.
- (3) Have a load rating of not less than the gross Vehicle weight.

Note: *Towing eyes shall only be used where the Vehicle can be moved freely. They must never be used to lift the Vehicle.*

5.3 Basic Chassis Design:

- (1) The Vehicle chassis, frame and/or unibody must remain unmodified between the vertical planes created by the original forward most and rear ward most suspension mounting points unless otherwise specified in these rules. Unibody or chassis may be seam welded.
- (2) Exterior body panels may be replaced or modified between and on either side of the vertical planes as described in Article 5.3(1). Any metal above the line formed by connecting the lowest point of all the windows, except the exterior roof panel, shall not be removed, including the pillars and the windshield frame, **unless by prior-approval by series scrutineer**. The exterior roof panel may be replaced with a composite panel.
- (3) The original OEM floorpan must remain fully intact between the vertical planes as described in Article 5.3(1) with exception of the transmission tunnel which can be enlarged so long as it is sealed and reconstructed with metal no thinner or weaker than the original. Transmission shifter locations may be enlarged or relocated in the transmission tunnel when non original transmissions are used.

- (4) The interior unibody must remain fully intact and unmodified around the entire outside perimeter of the Vehicle, between and inside the front and rear vertical planes as described in Article 5.3(1) from the original floorpan at the lowest horizontal plane to the roof at the highest horizontal plane, with exception of allowances given in Article 5.3(1) and (3).
- (5) Other interior unibody structures may be removed between and inside the vertical planes described in Article 5.3(1) that are not part of the original floorpan or outside perimeter or the unibody. These items can include the original rear window parcel shelf, interior tabs and structures for interior trim panels, various tabs or mounts for unused OEM steering columns and pedal boxes, OEM battery boxes and mounts, and unused OEM windshield wiper motor mounts and dividers not part of the original firewall structure. Any other items, - mounts, or structures intended for removal from the unibody must receive prior approval in writing from the D1NZ Series Scrutineer.
- (6) Rear suspension tower cross-members/bracing located at the top of the rear suspension towers may be removed from the unibody provided a suitable replacement structure of equivalent strength is installed in the same position following removal.
- (7) Any unibody panels or part thereof not listed above for removal from the unibody structure should be considered non-removable. Where a requirement arises a request must be made to the Series scrutineer including details, and prior written approval received.
- (8) Any holes must be filled in with an appropriate grommet or welded closed. This is a basic safety requirement.
- (9) Vehicles must be an approved series production Unibody chassis.
- (10) Small diameter non-structural reinforcing to replace bent panels front and rear is allowed when it becomes uneconomical to repair factory bodywork. You may construct framing to hold non critical parts (e.g. bumpers, coolers and lights). These must not be 'Ram Bars' (e.g. designed to take hits with little damage) and should be of similar strength to OEM.
- (11) Guard tubing is allowed but only for the sole purpose of tyre clearance. No core chassis structure may be modified. All modifications shall be carried out to a professional standard and should totally encompass the wheel/tyre/suspension assembly between the front and rear strut towers.
Note: *Vehicles with modified bodywork shall be subject to approval by the Series Scrutineer prior to event entry.*
- (12) Firewall modification for the purpose of access and clearance shall be authorised by the Series Scrutineer including:
 - exhaust clearance,
 - ease of maintenance (bellhousing bolt access) or
 - in the case of a FWD motor being installed in RWD configuration (for example 4AGE 20v or SR20DET (GTiR)),
 - distributor/water piping clearance (a section of 120mm x 120mm may be cut but must be boxed in again with a similar grade steel and totally seal the engine bay from the passenger compartment)
- (13) The strut towers must remain in the factory locations and may not be moved. This will be measured from the firewall.
- (14) Basic minimal floor modification for onboard jacks is permitted. Only two rear jacks, that only lift the rear wheels are permitted. They may only be air operated externally. No onboard reservoir or operation is permitted.

6.0 VEHICLE INTERIOR

- 6.1 The vehicle interior is free, provided compliance with Appendix Two, Schedule A and/or Appendix Five, Schedule DR is maintained.

- 6.2 Seats:** A passenger seat is optional, however where fitted the passenger seat must be a Competition Seat in compliance with Appendix 2 Schedule A.
- 6.3** Cockpit ventilation is free.
- 6.4** The Vehicle's cabin and boot must be completely empty from loose objects while competing.
- 6.5** Dry Sump Oil and/or Coolant Reservoir Tanks, and Water Sprayer Tanks inside the cockpit must be securely mounted to withstand forces of up to 25g. It is the competitors responsibility to provide proof of compliance. Oil Tanks must use a suitable sealing cap preventing spillage or fumes, and be externally vented. Maximum reservoir capacity is 20litres.

7.0 ENGINE SPECIFICATIONS

- 7.1 Drivetrain Modifications:** All drivetrain modifications are free, provided compliance with Schedule A is maintained, and excepting the following:
- 7.1.1 Engine Conversions:** All engine conversions are permitted provided they are to a professional and safe manner.
- NOTE:** *The engine placement shall remain as close to the original location as possible. Unless originally mounted so, the mating face of the engine to gearbox may not be behind the predominant vertical plane of the front firewall, excluding scuttle panels etc. It is advised to contact the Series Scrutineer prior to any conversion.*
- 7.2 Lubrication System:** is free, provided compliance with Schedule A and Article 6.5 is maintained.
- 7.3 Cooling System:** is free, provided compliance with Schedule A and Article 6.5 is maintained. Watersprayers for radiators/intercoolers are permitted so long as no leaks/fluids are present on track, start line or scrubbing area.
- 7.4 Oil Catch Tanks:** Shall be fitted to engines with open circuit crankcase breathing systems in compliance with Schedule A.

8.0 FUEL and AIR SYSTEMS

- 8.1** Fuel tanks, pumps, lines, fittings and components must comply with Schedule A, all fuel system components must be suitably placed and protected from risk of impact.
- 8.2** Air intake and filtration systems are free, but must comply with Article 5.1(7)
- 8.3 Fuel:** The only fuels authorised for use in competing vehicles at any Round of this Series is as per Appendix Two, Schedule A, Article 3.9.
- 8.4 Fuel additives - N20 / NOS:** Free, provided compliance with Schedule DR is maintained. Plastic Bottle brackets are not permitted.

9.0 TRANSMISSION

- 9.1** Gearboxes are free, in compliance with Schedule A provided a minimum of two(2) forward gears, and one(1) reverse gear are fitted, to be operable by the driver when seated in the normal driving position. The vehicle must be able to move from standstill under its own power during competition.
- 9.2** Sequential shift operation is permitted. All factors of shifting procedure must be mechanically operated. No pneumatic or electronic operated gearshifting allowed.
- 9.3** Clutch, drive-shaft/s, drive-joints, and mounts are free. The placement shall remain as per standard manufacture.

9.4 Differential: The differential is free, provided that it complies with Article 5.3.

9.5 Final Drive: The final drive is not permitted to be adjusted from the cockpit.

10.0 EXHAUST

10.1 Exhaust System:

- (1) All modifications are free provided compliance with Schedule A and DR is maintained. All non-wastegate exhaust systems must exit outside the outer bodywork of the vehicle behind the drivers/passengers door no higher than 300mm from ground level, and are not to protrude more than 150mm beyond the bodywork.
- (2) Venting wastegates to atmosphere is permitted under the following conditions:
 - (a) Any wastegate exhaust noise does not exceed 95db at any time, and
 - (b) The wastegate exhaust exits the outer bodywork of the vehicle behind the drivers/passengers door no higher than 300mm from ground level and do not protrude more than 150mm beyond the bodywork, or
 - (c) Exit below the engine bay facing to the ground, level with or below, the lowest part of the body or drivetrain, not rearward of the A pillar and with no fuel or brake lines or combustible components present within 300mm of the exit pipe opening, or
 - (d) Exit facing directly up through the bonnet, past the bodywork but protruding no more than 30mm. The wastegate pipe must have a cross welded into the exit opening, and must point emissions directly up. Emissions directed forward / rearward / sideward are not be permitted, or
 - (e) Exit through the front lower guard area past the bodywork but protruding no more than 30mm, with a cross welded in at the exit opening, pointing at a downward angle and no higher than 300mm from ground level.

Notes:

(1) *Wastegate systems are considered an integral part of the exhaust system and are subject to the same noise emission limits as the exhaust system.*

(2) *The wastegate allowances as described above only pertain to vehicles competing under this Schedule D1. Vehicles competing in events not covered by Schedule D1 must comply with Schedule A.*

10.2 Exhaust Noise: shall not exceed 95db at any time including wastegate exhaust.

11.0 ELECTRICAL SYSTEM

11.1 No aspect of the car may be adjusted remotely via telemetry once the car is on the track.

11.2 Batteries:

- (1) All batteries shall be securely mounted and have the live terminal adequately covered.
- (2) Batteries located in the cockpit shall;
 - Be mounted in accordance with Appendix 2, Schedule A, Article 5.5.
 - For 'unsealed' batteries an independently attached leak-proof box vented to the Vehicle exterior is required.
 - For a sealed battery (i.e. may be fitted in any orientation without any loss of fluid) may be mounted in the cockpit without a leak proof box.

- 11.3** All loose wires must be tied up safely.
- 11.4** Standard functional front windscreen wipers are required to be fitted that is capable of clearing the windscreen of water at all Vehicle speeds. Alternatively, suitable windscreen clearing substances may be used in their absence.
- 11.5** Functional demisting equipment must be fitted, or suitable antifog substance applied.
- 11.6 Headlights and Taillights:**
- (1) OEM Headlights / Taillights, or replica covers can be installed. Covers must have functioning lights in the same original position with the same effect as the OEM lighting.
 - (2) All headlights and taillights shall be intact and operational at the commencement of the Round.
 - (3) Strobes, HID, neon tubing and other ancillary lighting equipment are permitted. No rear facing strobes are permitted at any time. Scrutineers reserve the right to deem ancillary lighting to be disabled if potentially dangerous to competition (ie: High Intensity lightbars or spotlights).
 - (4) Where a light is damaged during an event, the Series Scrutineer or Nominated Scrutineer shall check the functionality of the lighting system for continued competition.
- 11.7 Passenger lights:**
- (1) A passenger light shall be fitted to the vehicle and illuminated in test sessions whenever a passenger is being carried. The passenger light shall:
 - (a) be yellow or orange LED with a minimum width of 170mm, and
 - (b) be mounted in the rear window on the left hand side of the vehicle, and
 - (c) be visible to chasing drivers
- 11.8 Front and Rear Facing Brake Lights:** Front and rear facing brake lights are mandatory for all vehicles under this schedule and shall:
- (1) be visible from the front, rear and from above the vehicle, and
 - (2) be centrally mounted at the top of the front and rear windows at the junction with the roof panel, and
 - (3) consist of LED strips with a minimum length of 813mm (32"), being the preferred colour of RED but shall not be yellow, orange, white or clear, and
 - (4) be connected to the vehicles primary brake light circuit in a manner that ensures the brake lights will illuminate at any time there is brake system pressure, and
 - (5) be of sufficient intensity to ensure they are clearly visible by other drivers and judges, and
 - (6) be in working condition at all times during the competition, and
 - (7) have no wiring components within reach of a seated driver, and
 - (8) penalties will be enforceable for any driver of a vehicle not displaying working brake-lights during an event.
- 11.9 Ignition/Circuit Breaker:** Shall be fitted in accordance to Schedule A Article 5.4(1).

12.0 SUSPENSION

12.1 Suspension:

- (1) Fitting of aftermarket suspension systems including but not limited to shock absorbers, springs, coil over kits, camber plates, sub frame bushes, castor arms, aftermarket tie-rod ends is permitted. Cut or modified springs are NOT permitted.
- (2) It is not permitted to change suspension design from Live Axle to Independent Rear Suspension or vice versa.
- (3) Live axle 3, 4 and 5 Link systems may have control arms removed for the purpose of antibind and safety/strength (*Refers to Historical 'AE86 Rule'*) No more than four(4) main control arms (forward/rear), and two(2) side control arms (Watts) can be used. The lower control arms must mount to the original body mounts; top control arm relocation is free.
- (4) It is permitted to change from Live Axle Leaf springs to a multilink system providing the lower control arms mount to the original forward and/or rear leaf spring mounting points on the body. The shock/coilover mounting position on the bodyshell may be relocated laterally only. It is not permitted to relocate forward or aft of the original lateral plane.
- (5) Aftermarket Suspension hub/knuckle replacement assemblies may be permitted at the Series Scrutineers sole discretion. Low volume hub/knuckle modification/manufacture must comply with Schedule A testing.
- (6) Cross members, suspension sub frames and live differential housings may be modified or substituted with OEM items provided their strength and integrity is kept or improved. Compliance with (7) and (9) below must be retained and measured proof may be required at any time by the Series Scrutineer.
- (7) Additional mounting tabs may be added to the subframe to relocate the suspension arm mounting points a maximum of 2 inches on any plane from the original mounting position, for THAT chassis designation. Mounting points can be on any plane as the attached suspension arm (refer Diagram 12.1(7) below) Additional mounting tabs may be added to facilitate the relocation -construction/ material must be of same or greater strength as the original mounting point. Other aspects of the mounting point (width, bolt size, etc) must remain as original.

Note: Beware Nissan subframe swaps, contact Series Scrutineer if any queries.

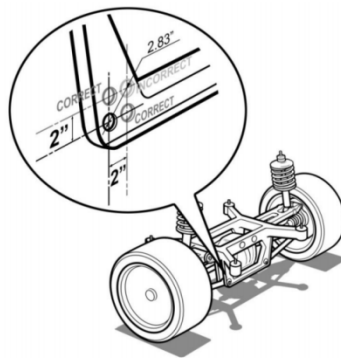

Diagram 12.1(7)

- (8) Original front suspension design type must remain: Double wishbone, MacPherson strut etc.
- (9) Subframe to chassis mounting point positions may not be modified/changed from original.

- (10) MacPherson strut upper mount pivot must remain within the centerline dimension of the OEM unaltered factory bolt pattern on the chassis (see illustration) The OEM pattern on the chassis must remain unaltered and be the only means of mounting the upper strut mount. All OEM bolt holes must be present and utilized.

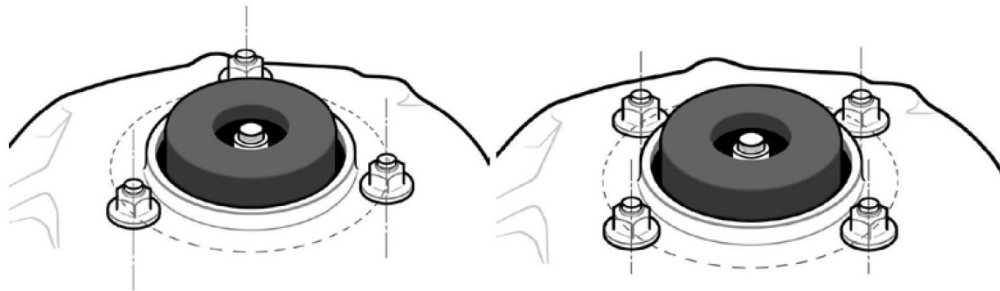

Diagram 12.1(10)

- (11) Suspension bushes may be substituted with aftermarket bushes of different elastic or metallic material.
- (12) The strut towers must remain in the factory locations and may not be moved. This will be measured from the firewall. You may clearance/slot the centre bore of the strut tower for the clearance of the shocktop where lock kits are installed providing that the structure is not weakened.
Note: Vehicles which have modified their vehicle in this way must gain entry consent from the Series Scrutineer prior to the event.
- (13) The Scrutineer reserves the right to inspect competitor vehicles at any time to inspect all suspension modifications.
- (14) a. In-cockpit / Driver adjustable suspension will not be allowed. Examples include, but not limited to, sway bars and electronic shock / damper adjusters such as the Tein EDFC.
b. No suspension changes or adjustments will be allowed between runs by any means including remotely. No actuators, servos, or motors of any kind will be allowed.

13.0 BRAKING SYSTEM

- 13.1 **Braking System:** Free, provided compliance with Schedule A is maintained.
- 13.2 An efficient hand brake shall be fitted to vehicles with a single circuit service brake system.
- 13.3 A Hydraulic handbrake is permitted.

14.0 STEERING

- 14.1 **Steering System:** Free, provided compliance with Schedule A is maintained.

Note: All welded or heated steering components shall be certified as required under Schedule A and the certificate must be produced when requested.

15.0 ROAD WHEELS AND TYRES

15.1 Wheel Requirements:

- (1) On all vehicles the upper 30% of the tyre located above the wheel hub centre must be covered by the bodywork when measured vertically.
- (2) All wheels, including spares, and the fastening systems, shall be in good condition, free from cracking or other structural defects/damage.

- (3) Where fitted, only one(1) wheel spacer/adaptor (per wheel) is permitted, manufactured in a single piece, of a maximum thickness of 50mm for a bolt-on adapter, or 25mm for a non-bolt-on spacer and a diameter not less than the mating hub diameter. Bolt-on spacers thicker than 25mm must have at least 5 studs. The use of high tensile wheel studs is recommended when using wheel spacers. Non bolt-on spacers thicker than 10mm must be fixed to the wheel. Bolt-on spacers must have the same amount of studs as the mating hub.
- (4) Only steel wheelnuts are permitted
- (5) All wheel trims and covers shall be removed.
- (6) Beadlockers, screws or any form of fixing tyres to wheels is not permitted

15.2 Tyre Requirements:

(1) Type and Width:

- **Pro-Class:** maximum tyre width is 265mm. "Road" or "Semi Slick" treaded tyres are permitted.
- **Pro-Sport Class:** maximum tyre width is 235mm. "Road" or "treaded" tyres are the only tyres permitted. "Slick" tyres are specifically prohibited.

- (2) All tyres must have grooves cut as permitted by the tyre manufacturer and no deeper than the original tread groove depth.
- (3) All tyres may not have studs fitted.
- (4) "Slicks", un-treaded tyres, or space saver tyres and tyre pressure control valves are not permitted.
- (5) All tyres must maintain a pressure of not less than 14.7psi (1bar) when at operating temperature, and/or not debeat due to a lower pressure than suitable for the wheel/tyre combination.
- (6) **Tyre modification:** The following modifications / treatments are specifically prohibited:
 - (a) Hand cut tread grooves
 - (b) Filing, buffing, or any other disguising of the tyre sidewall
 - (c) Tyre warmers, chemical treatments or any means of artificially enhancing tyre performance.

16.0 GENERAL

- 16.1 Nuts, bolts, circlips, pins, springs, clips, paintwork, coolants and lubricants are free.